

enjoy your new

SAVE-A-LOAD®

**Made in
USA**

MODEL: ATR-20

LOCKING LOAD BAR HOLDER

KENWORTH:

- 1) Bolt the bar holder to the cab-extender support, using existing bolts.
- 2) Repeat the process to install the bottom foot tray.

PETERBILT:

- 1) Screw an L-bracket with the longest side extended down, to the cab-extender support, using the upper-most holes. For an alternative installation, screw the L-bracket directly to the cab wall placing the indentation on the L-bracket over the rivet line for a flush fit.
- 2) Bolt the bar holder to the L-bracket.
- 3) Repeat the process to install the bottom foot tray.

MACK / WHITE / GMC:

- 1) Drill two holes in the cab-extender support from the top to permit the bar holder to be mounted centered in the corner. Use the small holes on the bar holder.
- 2) Bolt the bar holder to the cab-extender support.
- 3) Repeat the process to install the bottom foot tray.

NAVISTAR / IH / VOLVO:

- 1) Bolt an L-bracket with the longest side extended down, to the rear of the cab using the upper-most holes.
- 2) Bolt the bar holder to the L-bracket.
- 3) Repeat the process to install the bottom foot tray.

FREIGHTLINER:

- 1) Bolt an L-bracket with the longest side extended down, to the rear of the cab using the upper-most holes.
- 2) Bolt the bar holder to the L-bracket.
- 3) Repeat the process to install the bottom foot tray.

NOTE: Allow adequate room between the bar holder and the foot tray for proper storage of load bars. Some installations may not require the use all of the hardware provided.

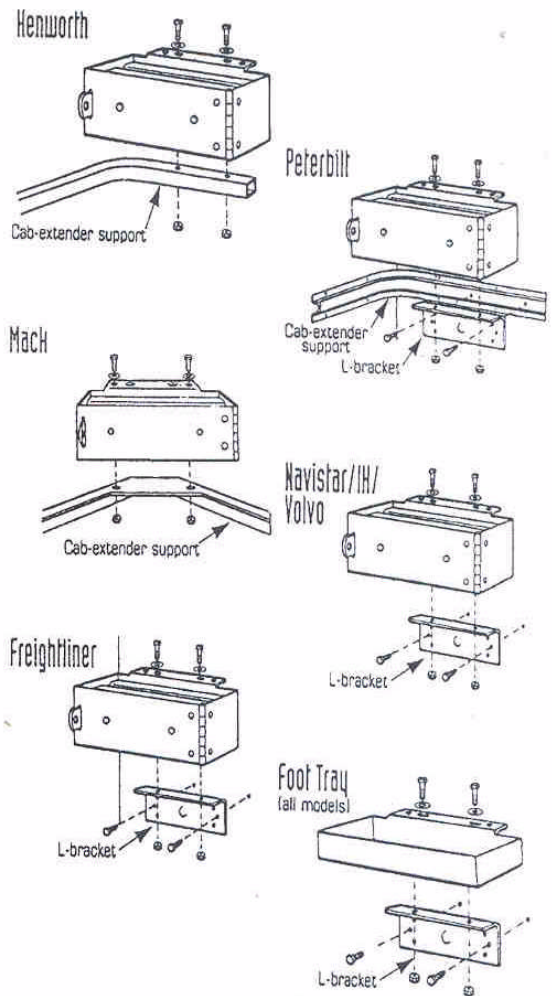

(800) 728-5623

www.saveaload.com



SAVE-A-LOAD, INC.

327-A West Tremont Avenue
Charlotte, North Carolina
28203